

Service manual Euromat M16-E2-TS 400 50Hz

Version: 2.00

Ident:

Series:

Pert-Number:



Chapter

baking chamber Euromat M16-E2-TS 400 50Hz - V:
door control butcher Euromat M16-E2-TS 400 50Hz - V:
104837 - door Euromat M16-E2-TS 400 50Hz - V:
electric slide Euromat M16-E2-TS 400 50Hz - V:
frame Euromat M16-E2-TS 400 50Hz - V:
installation-room Euromat M16-E2-TS 400 50Hz - V:

Service manual

baking chamber Euromat M16-E2-TS 400 50Hz

Version:

Ident:

Series:

Pert-Number:

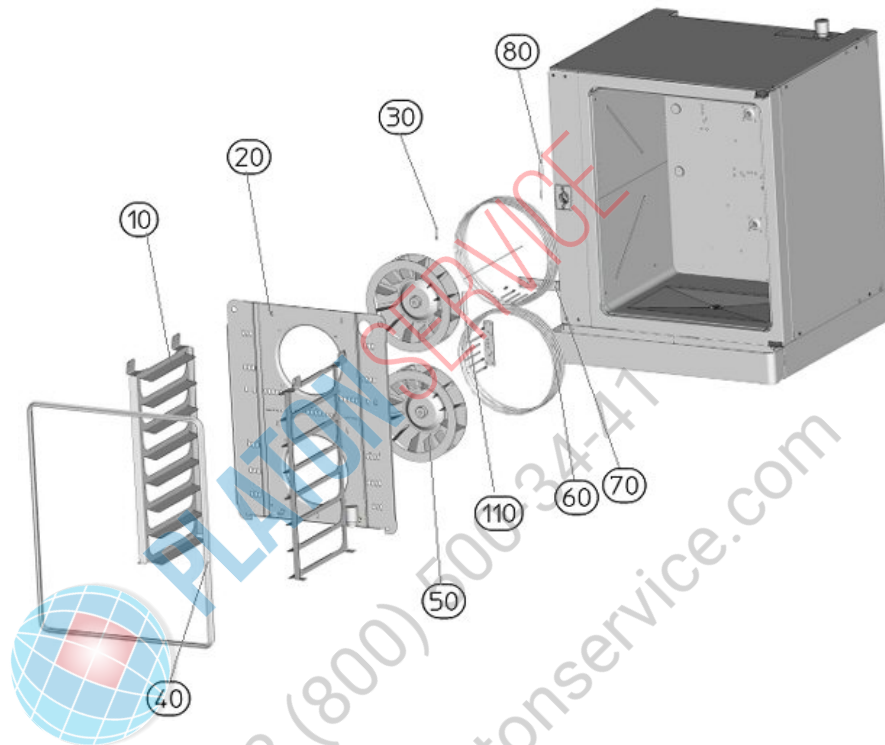

Chapter

tray runners Euromat M16-E2-TS 400 50Hz - V:

- 38725 - drain seal
- [030] - 29738 - ProClean jets complete
- [040] - 38604 - door seal
- [050] - 33862 - fan wheel
- [060] - 38146 - heater 9000 W
- [060] - 38533 - heater 7000 W
- [070] - 36010 - seal chamber heater; Attention replaced by 9800-100-001
- [070] - 9085-100-001 - seal chamber heater
- [080] - 36287 - thermo element Typ K
- [110] - 9030-141-001 - thermometer PT500 with corrugated hose

Part: drain seal

Pert-Number: 38725



Part: ProClean jets complete

Pert-Number: 29738

Depending on the type of cleaning system, either fresh water or fresh water with liquid Pro Clean Cleaner/Rinse will be sprayed by the ProClean jets into the oven. The rotating motion of the jet head will evenly spray the liquid around the oven. Please notify your customer to only use the recommended cleaning and rinse agents from the manufacturer. Check that the ProClean jets easily spray. Please note that in the Dibas series only short jets are used.



Part: door seal

Pert-Number: 38604

The door seal is glued with transparent heat resistant silicone (order number 60375) around the radii on the corners and long distances in between. Should the door seal be exchanged then all the silicone must be removed by using a knife. Clean the door tracks and any silicone particles. Make sure when placing the new seal that it is completely in the frame. The seal needs to be pressed around the connecting piece on the top and bottom and in front of the oven with a broach so that it can "breathe". The door seal is a spare part and can be ordered under the number 38604 as cut goods 2,4 m long. Please notice the assembly instructions how to replace the seal.



Part: fan wheel

Pert-Number: 33862

The manufacturer tested the fan wheel for imbalance. Keep away any direct heat from the fan wheel for e.g. Blow lamps, otherwise the wheel will not run smoothly. An imbalance of the wheel will damage the motor and yield unsatisfactory baking results. The fan wheel is attached to the motor shaft and a fan wheel removal device must be used when replacing it. At any sign of imbalance the fan wheel must be replaced to prevent further damage.



Part: heater 9000 W

Pert-Number: 38146

The ring heater is attached by two securing loops on the welded bolts on the oven wall with two nuts. The heater flange is secured with 5 hexagonal screws. The ring heater can be replaced. When replacing the ring heater the seal must be also be replaced. Work with thread free hexagonal screws to prevent damage that may be caused by heat. Read the "part documents" for this article.



Part: heater 7000 W

Pert-Number: 38533



Part: seal chamber heater; Attention replaced by 9800-100-001

Pert-Number: 36010



Part: seal chamber heater

Pert-Number: 9085-100-001

When replacing the heater the seal must be replaced as well.



Part: thermo element Typ K

Pert-Number: 36287

=> replaced by 104610 The thermo element type K is used as an oven probe. The oven probe controls the oven temperature. The working range is between 30 - 250°C. Please note the polarity (+/-) when replacing the thermo elements. To prevent false measurements the probe must be inserted as far as it will go. Ensure that the oven probe feeds through the fan cover into the oven. The probe must not be in contact with the fan cover - false measurements or even deactivating the safety chain may be the result of coming in contact. If the probe is too short and does not fit into the oven, a probe extension is necessary. Please notice the assembly instructions MH_14-0511-017.



Part: thermometer PT500 with corrugated hose

Pert-Number: 9030-141-001

The core sensor is a four-point probe (4xPT 500). Of the four measured values are working with the coldest value. In normal function of the probe on X22 PIN 3 / 4 is bridged. If the PT 500 probe against a PT 100 sensors to be replaced, so the bridge must be removed. Warning, this is PT 100 sensor in the measurement result significantly less accurate. Please advise the customer points out that the sensor is not suitable for lifting or turning the food being cooked. The needle sensor has a sensitive tip which can be damaged by improper use. A temperature adjustment with the needle probe is not possible. When a sensor failure is working with the core temperature is not possible. The PT 500 is always replaced as a whole, this must not be paid to the polarity. To test the PT 500, please use the table in "Documents" link.



Service manual

tray runners Euromat M16-E2-TS 400 50Hz

Version:

Ident:

Series:

Pert-Number:

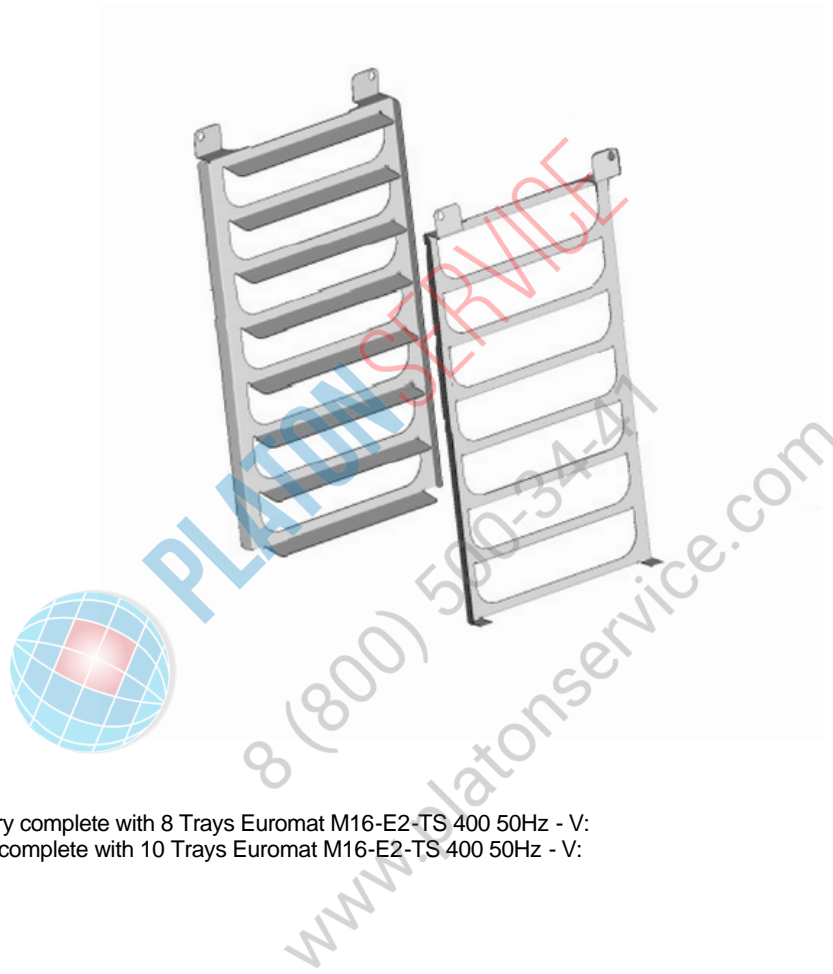

Chapter

46410 - tray runners butchery complete with 8 Trays Euromat M16-E2-TS 400 50Hz - V:

47249 - tray runners gastro complete with 10 Trays Euromat M16-E2-TS 400 50Hz - V:

Service manual

tray runners butchery complete with 8 Trays Euromat M16-E2-TS 400 50Hz

Version:

Ident:

Series:

Pert-Number: 46410

This part can be ordered.



Chapter

- 104462 - tray runners left, 8 trays
- 104733 - tray runners right, 8 trays



8 (800) 500 34 41
www.platonservice.com

Part: tray runners left, 8 trays

Pert-Number: 104462

Part: tray runners right, 8 trays

Pert-Number: 104733



PLATON SERVICE

8 (800) 500-34-47

www.platonservice.com

Service manual tray runners gastro complete with 10 Trays Euromat M16-E2-TS 400 50Hz

Version:

Ident:

Series:

Pert-Number: 47249

This part can be ordered.



Chapter

08774 - tray runners left, 6 trays
30547 - tray runners right, 10 trays



PLATON SERVICE
8 (800) 500-34-47
www.platonservice.com

Part: tray runners left, 6 trays

Pert-Number: 08774

Part: tray runners right, 10 trays

Pert-Number: 30547



PLATON SERVICE

8 (800) 500-34-47

www.platonservice.com

Service manual door control butcher Euromat M16-E2-TS 400 50Hz

Version:

Ident:

Series:

Pert-Number:



Chapter

TS350 control Euromat M16-E2-TS 400 50Hz - V:

Service manual

TS350 control Euromat M16-E2-TS 400 50Hz

Version:

Ident:

Series:

Pert-Number:



Chapter

38159 - LCD screen

[010] - 30026 - operating foil M16 TS 350 saffron

[011] - 101497 - operating foil B8 TS 350 grey

[030] - 93112 - circuit board TS300/350

[040] - 93115 - eprom V1.24

[050] - 93116 - eprom V1.37

[060] - 30866 - hinge plate with bolt ahead left

[070] - 30868 - hinge plate with bolt ahead right

[080] - 30867 - hinge plate with bolt above left

[090] - 30869 - hinge plate with bolt above right

Part: LCD screen

Pert-Number: 38159

Part: operating foil M16 TS 350 saffron

Pert-Number: 30026

Part: operating foil B8 TS 350 grey

Pert-Number: 101497



Part: circuit board TS300/350

Pert-Number: 93112

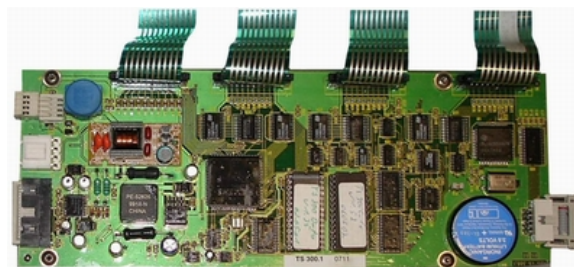

Vor Arbeitsbeginn bitte Netztrennung vornehmen.

Part: eprom V1.24

Pert-Number: 93115



Part: eprom V1.37

Pert-Number: 93116



Part: hinge plate with bolt ahead left

Pert-Number: 30866



Part: hinge plate with bolt ahead right

Pert-Number: 30868

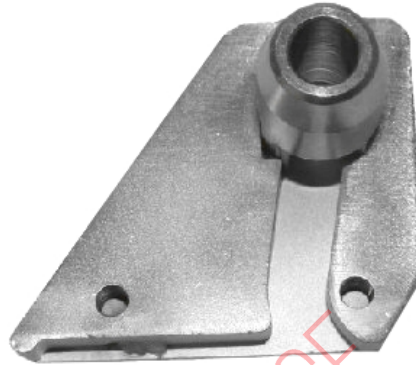

Part: hinge plate with bolt above left

Pert-Number: 30867

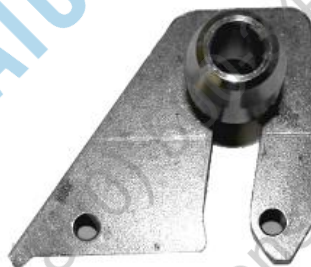

Part: hinge plate with bolt above right

Pert-Number: 30869



Service manual door Euromat M16-E2-TS 400 50Hz

Version:

Ident:

Series:

Pert-Number: 104837

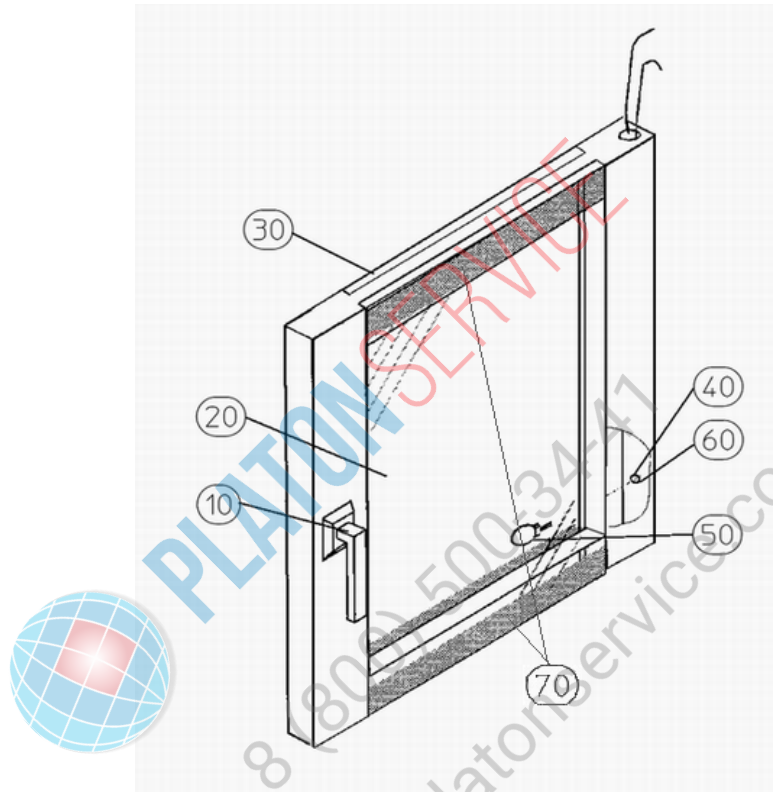

Chapter

handle element Euromat M16-E2-TS 400 50Hz - V:
104837 - sealing pane Euromat M16-E2-TS 400 50Hz - V:
viewing pane Euromat M16-E2-TS 400 50Hz - V:

- [040] - 38642 - halogen sockets
- [050] - 101731 - halogen lamp 12V 10W
- [060] - 34312 - porcelain clamp
- [070] - 38155 - rubber-metal buffers

Part: halogen sockets

Pert-Number: 38642



Part: halogen lamp 12V 10W

Pert-Number: 101731

When changing the halogen lamps please make sure that the lamps do not come in contact with hand sweat. Hand sweat will burn into the glass bulb and reduces the life of the halogen lamp. Please use the appropriate gloves.



Part: porcelain clamp

Pert-Number: 34312

The porcelain clamp can not be chipped or damaged. Ensure the halogen lamps are secure.



Part: rubber-metal buffers

Pert-Number: 38155

Is fixed between door glass outside and sealing pane.



PLATON SERVICE

8 (800) 500-34-47

www.platonservice.com

Service manual handle element Euromat M16-E2-TS 400 50Hz

Version:

Ident:

Series:

Pert-Number:

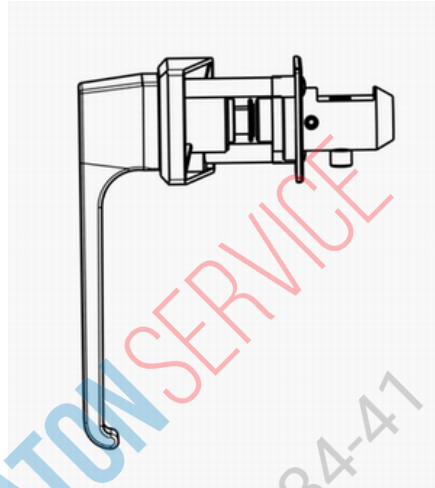

Chapter

2500-402-043 - door handle left complete Euromat M16-E2-TS 400 50Hz - V:
103797 - door handle right complete Euromat M16-E2-TS 400 50Hz - V:



PLATON SERVICE
8 (800) 300-34-47
www.platonservice.com

Service manual door handle left complete Euromat M16-E2-TS 400 50Hz

Version:

Ident:

Series:

Pert-Number: 2500-402-043

This part can be ordered.

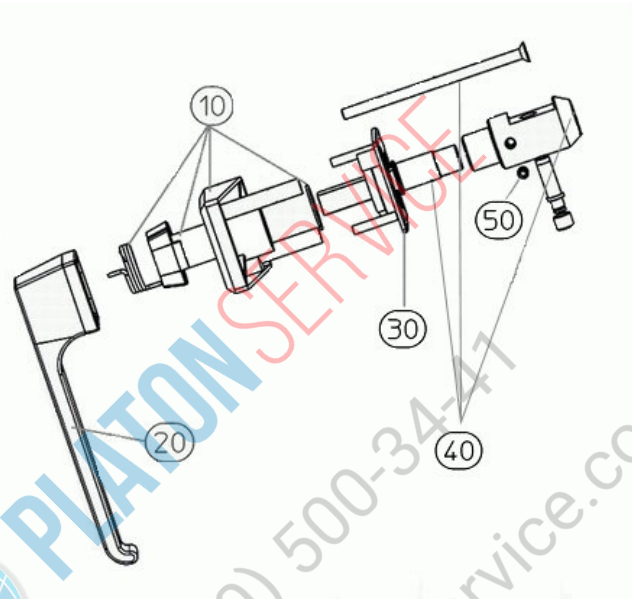

Chapter

31294 - handle element TS left complete assembled Euromat M16-E2-TS 400 50Hz - V:
2500-402-046 - service-kit axis/sash fastener Euromat M16-E2-TS 400 50Hz - V:

2500-402-043 - door handle EM left complete
[030] - 38152 - counterpiece
[050] - 42725 - threaded pin M8x8 DIN 913

Part: door handle EM left complete

Pert-Number: 2500-402-043

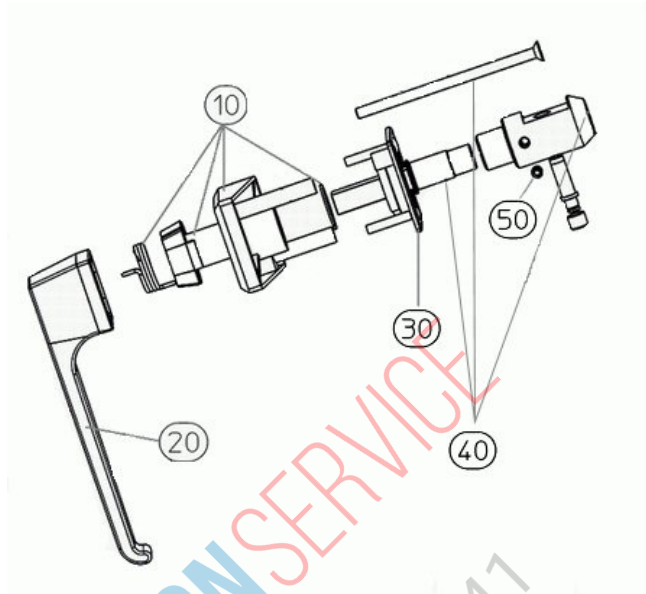

Part: counterpiece

Pert-Number: 38152



Part: threaded pin M8x8 DIN 913

Pert-Number: 42725



Service manual

handle element TS left complete assembled Euromat M16-E2-TS 400 50Hz

Version:

Ident:

Series:

Pert-Number: 31294

This part can be ordered.



Chapter

31294 - handle element left assembled

[010] - 36715 - connector piece

[020] - 42371 - door handle spring, left-hinged

[030] - 42377 - support

[040] - 42692 - retainer ring

Part: handle element left assembled

Pert-Number: 31294



Part: connector piece

Pert-Number: 36715

The connecting piece serves to set the necessary pull emergency of the handle. The plastic of the connecting piece must not be damaged. e.g. creasing from door spring. Damage can cause early locking of the door spring. When setting ensure that the handle remains in a horizontal position on its own otherwise the setting is too loose. Just as in closing the door handle must remain in a vertical position otherwise the setting is too stiff.



Part: door handle spring, left-hinged

Pert-Number: 42371

Note when installing if a right or left door spring should be used. The door spring can not be damaged. Adjust the spring when first installing to the works position. Incorrect positioning causes spring hardening.



Part: support

Pert-Number: 42377



Part: retainer ring

Pert-Number: 42692

To install/remove the retaining ring use a retaining ring gripper.



PLATON SERVICE

8 (800) 500-34-47

www.platonservice.com

Service manual

service-kit axis/sash fastener Euromat M16-E2-TS 400 50Hz

Version:

Ident:

Series:

Pert-Number: 2500-402-046

This part can be ordered.



Chapter

- 2500-402-046 - service-kit axis/sash fastener TS
- [010] - 2500-402-044 - sash fastener
- [020] - 2500-402-032 - axle TS
- [030] - 42719 - screw M6 x 120 DIN7991

Part: service-kit axis/sash fastener TS

Pert-Number: 2500-402-046



Part: sash fastener

Pert-Number: 2500-402-044

The sash fastener setting screw regulates the door contact (door end switch). First the grub screw must be loosened on the side of the cone. Then adjust the setting screw. Once adjusted put 1-2 drops of screw lack on the grub screw to avoid shifting. The sash fastener can not be too tight or too loose. TIP: Use a piece of paper, slide it between the door and the door seal. The paper should easily come out of the closed door when pulled.



Part: axle TS

Pert-Number: 2500-402-032

Part: screw M6 x 120 DIN7991

Pert-Number: 42719



PLATON SERVICE

8 (800) 500-34-47

www.platonservice.com

Service manual door handle right complete Euromat M16-E2-TS 400 50Hz

Version:

Ident:

Series:

Pert-Number: 103797

This part can be ordered.

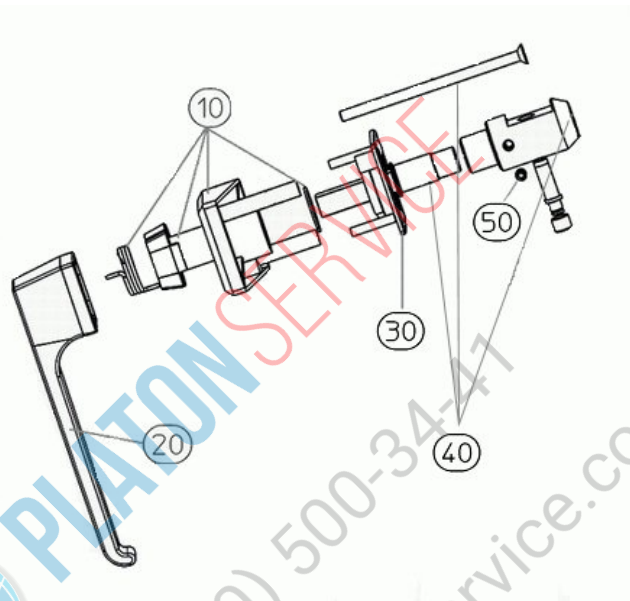

Chapter

31204 - handle element TS right complete assembled Euromat M16-E2-TS 400 50Hz - V:

2500-402-046 - service-kit axis/sash fastener Euromat M16-E2-TS 400 50Hz - V:

2500-402-042 - door handle EM right complete

[020] - 103685 - handle

[030] - 38152 - counterpiece

[050] - 42725 - threaded pin M8x8 DIN 913

Part: door handle EM right complete

Pert-Number: 2500-402-042

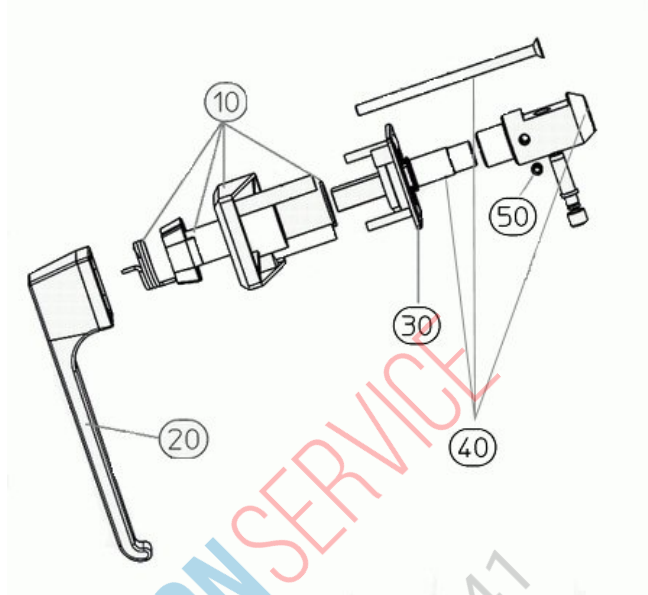

Part: handle

Pert-Number: 103685



PLATON SERVICE
8 (800) 500-34-41
www.platonservice.com

Part: counterpiece

Pert-Number: 38152



Part: threaded pin M8x8 DIN 913

Pert-Number: 42725



PLATON SERVICE

8 (800) 500-34-47

www.platonservice.com

Service manual

handle element TS right complete assembled Euromat M16-E2-TS 400 50Hz

Version:

Ident:

Series:

Pert-Number: 31204

This part can be ordered.



Chapter

31204 - handle element right assembled

[010] - 36715 - connector piece

[020] - 42373 - door handle spring, right-hinged

[030] - 42377 - support

[040] - 42692 - retainer ring

Part: handle element right assembled

Pert-Number: 31204



Part: connector piece

Pert-Number: 36715

The connecting piece serves to set the necessary pull emergency of the handle. The plastic of the connecting piece must not be damaged. e.g. creasing from door spring. Damage can cause early locking of the door spring. When setting ensure that the handle remains in a horizontal position on its own otherwise the setting is too loose. Just as in closing the door handle must remain in a vertical position otherwise the setting is too stiff.



Part: door handle spring, right-hinged

Pert-Number: 42373

Note when installing if a right or left door spring should be used. The door spring can not be damaged. Adjust the spring when first installing to the works position. Incorrect positioning causes spring hardening.



Part: support

Pert-Number: 42377

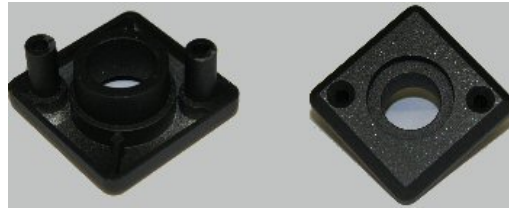

Part: retainer ring

Pert-Number: 42692

To install/remove the retaining ring use a retaining ring gripper.



PLATON SERVICE

8 (800) 500-34-47

www.platonservice.com

Service manual

service-kit axis/sash fastener Euromat M16-E2-TS 400 50Hz

Version:

Ident:

Series:

Pert-Number: 2500-402-046

This part can be ordered.



Chapter

- 2500-402-046 - service-kit axis/sash fastener TS
- [010] - 2500-402-044 - sash fastener
- [020] - 2500-402-032 - axle TS
- [030] - 42719 - screw M6 x 120 DIN7991

Part: service-kit axis/sash fastener TS

Pert-Number: 2500-402-046



Part: sash fastener

Pert-Number: 2500-402-044

The sash fastener setting screw regulates the door contact (door end switch). First the grub screw must be loosened on the side of the cone. Then adjust the setting screw. Once adjusted put 1-2 drops of screw lack on the grub screw to avoid shifting. The sash fastener can not be too tight or too loose. TIP: Use a piece of paper, slide it between the door and the door seal. The paper should easily come out of the closed door when pulled.



Part: axle TS

Pert-Number: 2500-402-032

Part: screw M6 x 120 DIN7991

Pert-Number: 42719



PLATON SERVICE

8 (800) 500-34-47

www.platonservice.com

Service manual sealing pane Euromat M16-E2-TS 400 50Hz

Version:

Ident:

Series:

Pert-Number: 104837

This part can be ordered.

Chapter

104837 - sealing pane B8 EM



PLATON SERVICE

8 (800) 500-34-41

www.platonservice.com

Part: sealing pane B8 EM

Pert-Number: 104837



PLATON SERVICE

8 (800) 500-34-47

www.platonservice.com

Service manual viewing pane Euromat M16-E2-TS 400 50Hz

Version:

Ident:

Series:

Pert-Number:

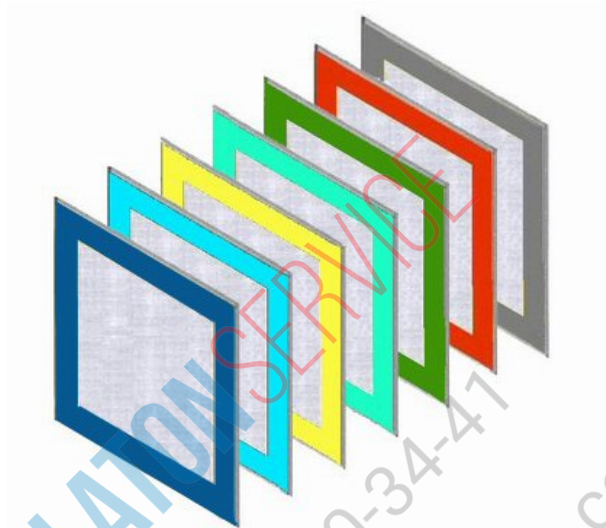

Chapter

25028 - ball catch MS

[010] - 104314 - door glass outside EUROMAT grey

[020] - 31029 - door glass outside EUROMAT red

[030] - 31026 - door glass outside EUROMAT green

[040] - 31025 - door glass outside EUROMAT turquoise green

[050] - 31027 - door glass outside EUROMAT yellow

[060] - 31030 - door glass outside EUROMAT turquoise blue

[080] - 104323 - door glass outside EUROMAT dark-blue

Part: ball catch MS

Pert-Number: 25028

The ball catch is a holder between the sealing and viewing pane. The ball catch can not be justified and on one side the sealing pane is glued with heat resistant Pactan. The tension level can be adjusted with a screwdriver.



Part: door glass outside EUROMAT grey

Pert-Number: 104314

Part: door glass outside EUROMAT red

Pert-Number: 31029

Part: door glass outside EUROMAT green

Pert-Number: 31026

Part: door glass outside EUROMAT turquoise green

Pert-Number: 31025

Part: door glass outside EUROMAT yellow

Pert-Number: 31027

Part: door glass outside EUROMAT turquoise blue

Pert-Number: 31030

Part: door glass outside EUROMAT dark-blue

Pert-Number: 104323

Service manual electric slide Euromat M16-E2-TS 400 50Hz

Version:

Ident:

Series:

Pert-Number:

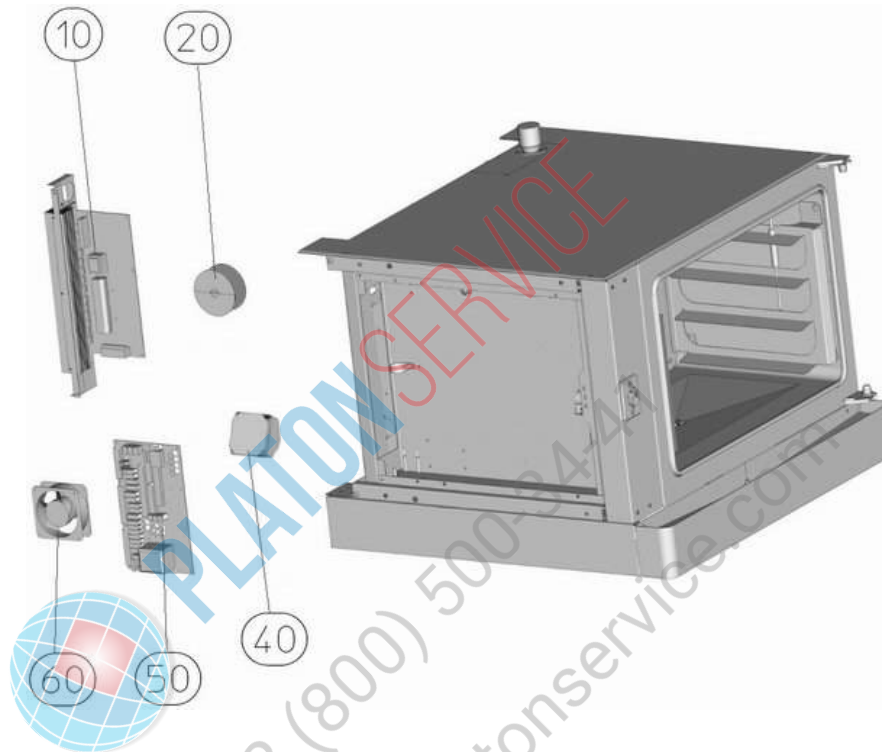

Chapter

- [010] - 93123 - triac setter 32A 400V (E200A)
- [020] - 38726 - ring core transformer
- [040] - 38400 - loudspeaker
- [050] - 101319 - circuit board with female multipoint connector
- [060] - 33906 - axial blower 15W

Part: triac setter 32A 400V (E200A)

Pert-Number: 93123

When exchanging the electronic circuit board, please note that electrostatic charge and its components can cause major damage. Therefore please make sure that before coming in contact with the circuit board that the circuit board and its metal frame are completely discharged. The triac controller controls the heater and the motor. Please read the article documents before installing or removing this part."



Part: ring core transformer

Pert-Number: 38726

The ring core transformer serves as a voltage supplier for the baking chamber interior lighting. The cables must be correctly installed when installing and removing this transformer."

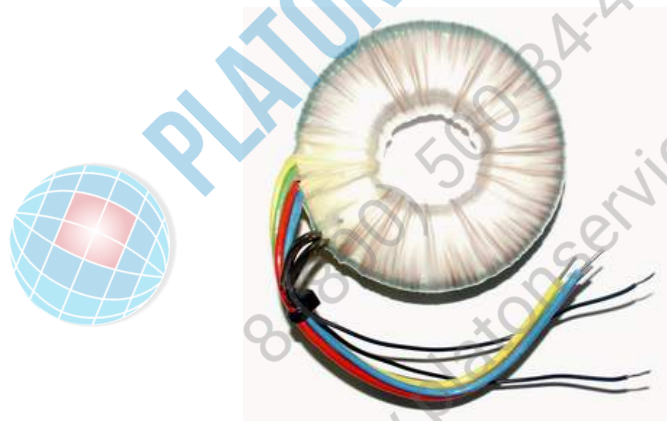

Part: loudspeaker

Pert-Number: 38400

The loud speaker signal serves as an acoustic signal. For example notification is given for "temperature reached". "end of program". As well as when opening the door a short gong will sound. If the gong does not work, first of all check the appliance settings. You can reach the menu point "Gong" by going to "Settings - Appliance Settings - Gong". Here you can set the volume and intervals of the sound. If the volume and interval is set to 0 no acoustic signal will be given. Test the gong, by going to the PC-Tool - Function Test. Warning! The PC-Tool- Function test is an endurance test and is not protected from overload!



Part: circuit board with female multipoint connector

Pert-Number: 101319



Part: axial blower 15W

Pert-Number: 33906

The axial blower regulates the temperature in the installation room. Warm air is blown outside and cool air blown inside the room. Please note the arrow direction of the air flow when installing the axial flow fan.



PLATON SERVICE
8 (800) 500-47
www.platonservice.com

Service manual frame Euromat M16-E2-TS 400 50Hz

Version:

Ident:

Series:

Pert-Number:

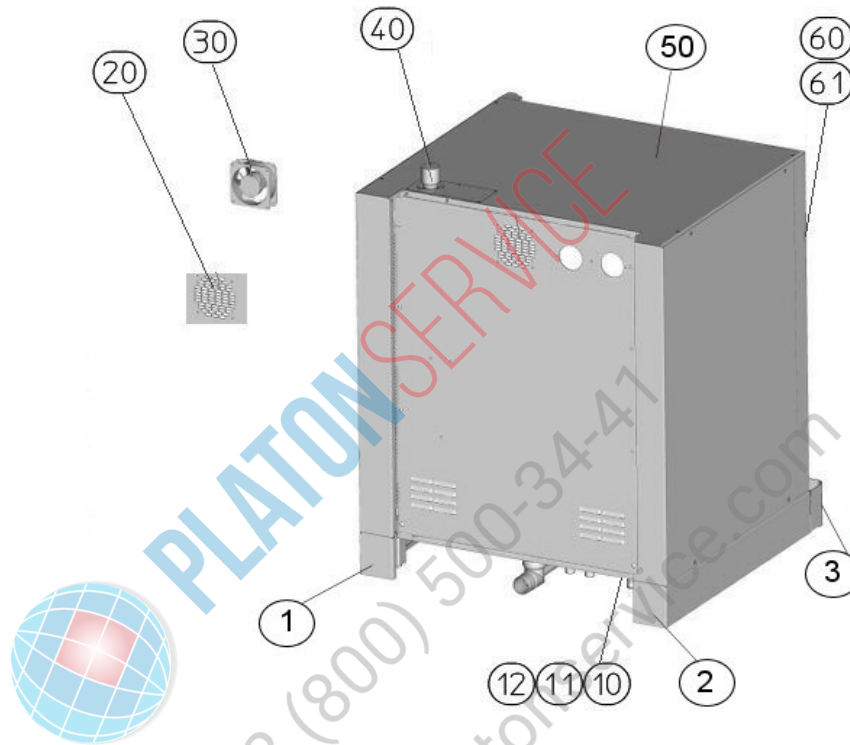

Chapter

blocks Euromat E2 with electrical latch Euromat M16-E2-TS 400 50Hz - V:
blocks Euromat E2 without electrical latch Euromat M16-E2-TS 400 50Hz - V:

- [001] - 102544 - front covering E2 right
- [002] - 102545 - front covering E2 left
- [003] - 31266 - drip tray riveted
- [010] - 101726 - socket
- [011] - 103815 - socket
- [012] - 25014 - supply line 32A with CEE-plug
- [020] - 33973 - axial fan cover
- [030] - 33906 - axial blower 15W
- [040] - 09307 - weight exhaust
- [050] - 102372 - inside cover short

Part: front covering E2 right

Pert-Number: 102544

Part: front covering E2 left

Pert-Number: 102545

Part: drip tray riveted

Pert-Number: 31266

Part: socket

Pert-Number: 101726



Part: socket

Pert-Number: 103815

Electrical plug for the exhaust hood



PLATON SERVICE
8 (800) 500-34-47
www.platonservice.com

Part: supply line 32A with CEE-plug

Pert-Number: 25014



Part: axial fan cover

Pert-Number: 33973

To avoid injury the axial fan cover must be installed correctly.



Part: axial blower 15W

Pert-Number: 33906

The axial blower regulates the temperature in the installation room. Warm air is blown outside and cool air blown inside the room. Please note the arrow direction of the air flow when installing the axial flow fan.



Part: weight exhaust

Pert-Number: 09307



Part: inside cover short

Pert-Number: 102372



PLATON SERVICE

8 (800) 500-34-47

www.platonservice.com

Service manual blocks Euromat E2 with electrical latch Euromat M16-E2-TS 400 50Hz

Version:

Ident:

Series:

Pert-Number:

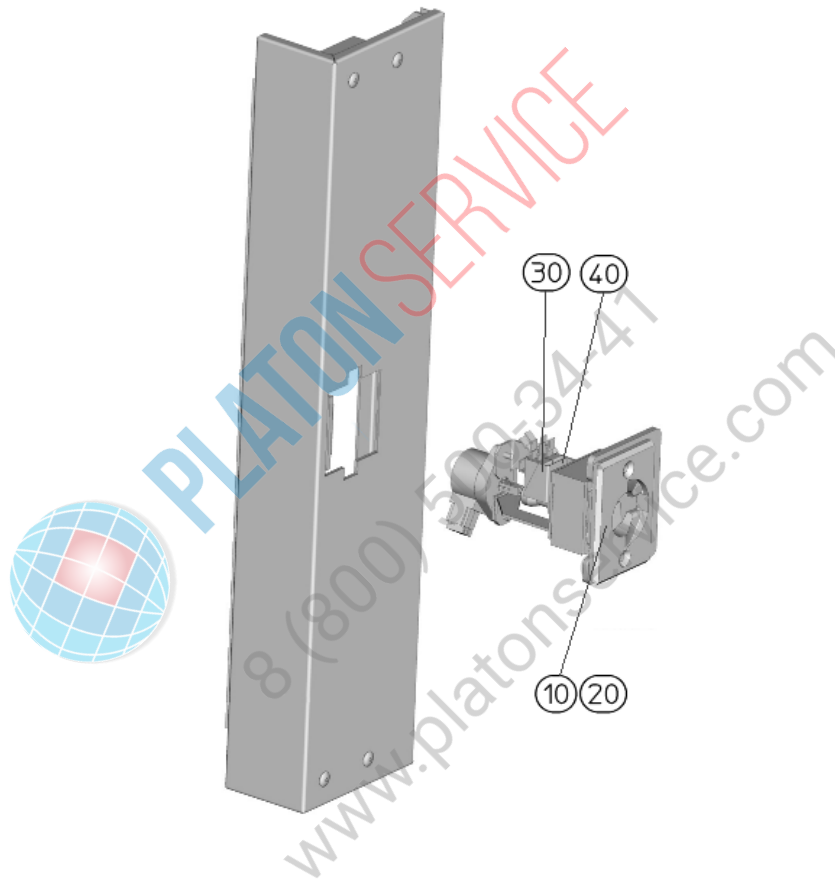

Chapter

- [010] - E2500-402-010 - door blocks right
- [020] - E2500-402-011 - door blocks left
- [030] - 36000 - micro switch
- [040] - 39061 - micro switch

Part: door blocks right

Pert-Number: E2500-402-010

This part replaces the article 105402. The spare parts are compatible applications.

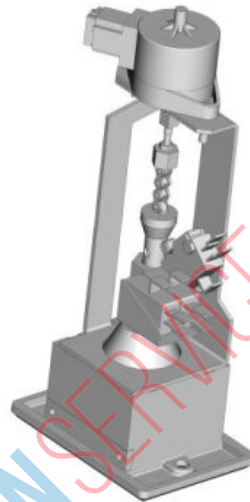

Part: door blocks left

Pert-Number: E2500-402-011

This part replaces the article 105402. The spare parts are compatible applications.



Part: micro switch

Pert-Number: 36000

Micro fuse with gold contact. The micro fuse must be closed by locked door.



Part: micro switch

Pert-Number: 39061

The micro fuse for door blocks with electrical door closures/Pro Clean switches the electrical door closure on for example the automatic self-cleaning program or door closure program is running.



PLATON SERVICE
8 (800) 5034-47
www.platonservice.com

Service manual blocks Euromat E2 without electrical latch Euromat M16-E2-TS 400 50Hz

Version:

Ident:

Series:

Pert-Number:

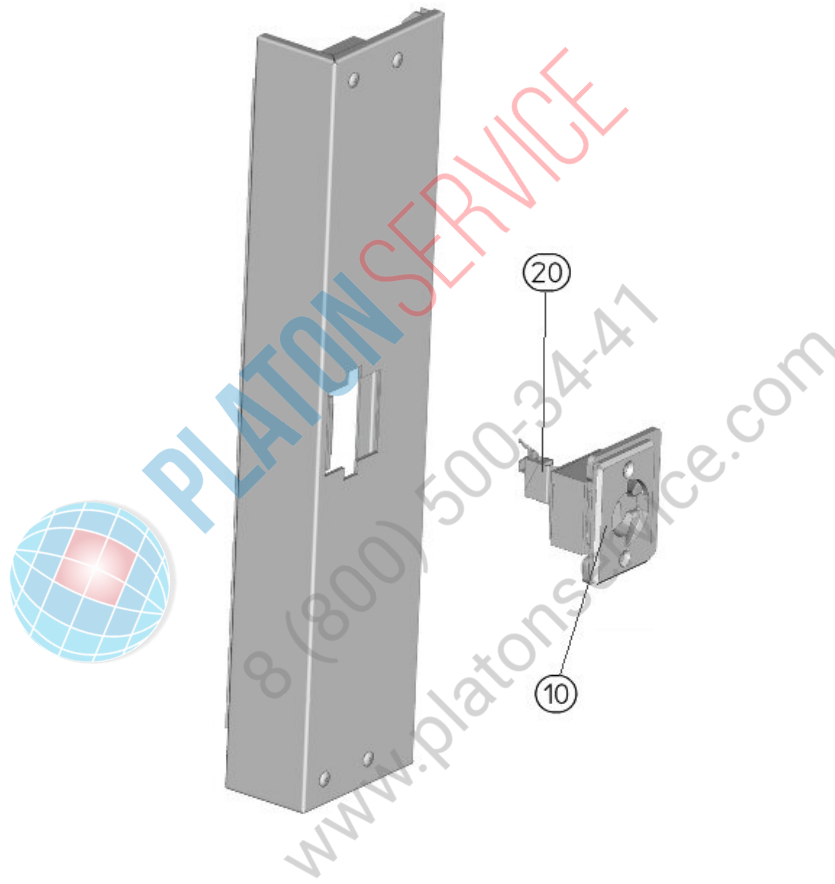

Chapter

37937 - door latch; Attention replaced by 9040-120-003

39061 - micro switch

9040-120-003 - bracket with inserted nuts PCL

Part: door latch; Attention replaced by 9040-120-003

Pert-Number: 37937



Part: micro switch

Pert-Number: 39061

The micro fuse for door blocks with electrical door closures/Pro Clean switches the electrical door closure on for example the automatic self-cleaning program or door closure program is running.



Part: bracket with inserted nuts PCL

Pert-Number: 9040-120-003

Door latch for furnace without electrical locking mechanism/pro Clean. The Door latch is to be used both for right and for left door stop.

Service manual installation-room Euromat M16-E2-TS 400 50Hz

Version:

Ident:

Series:

Pert-Number:

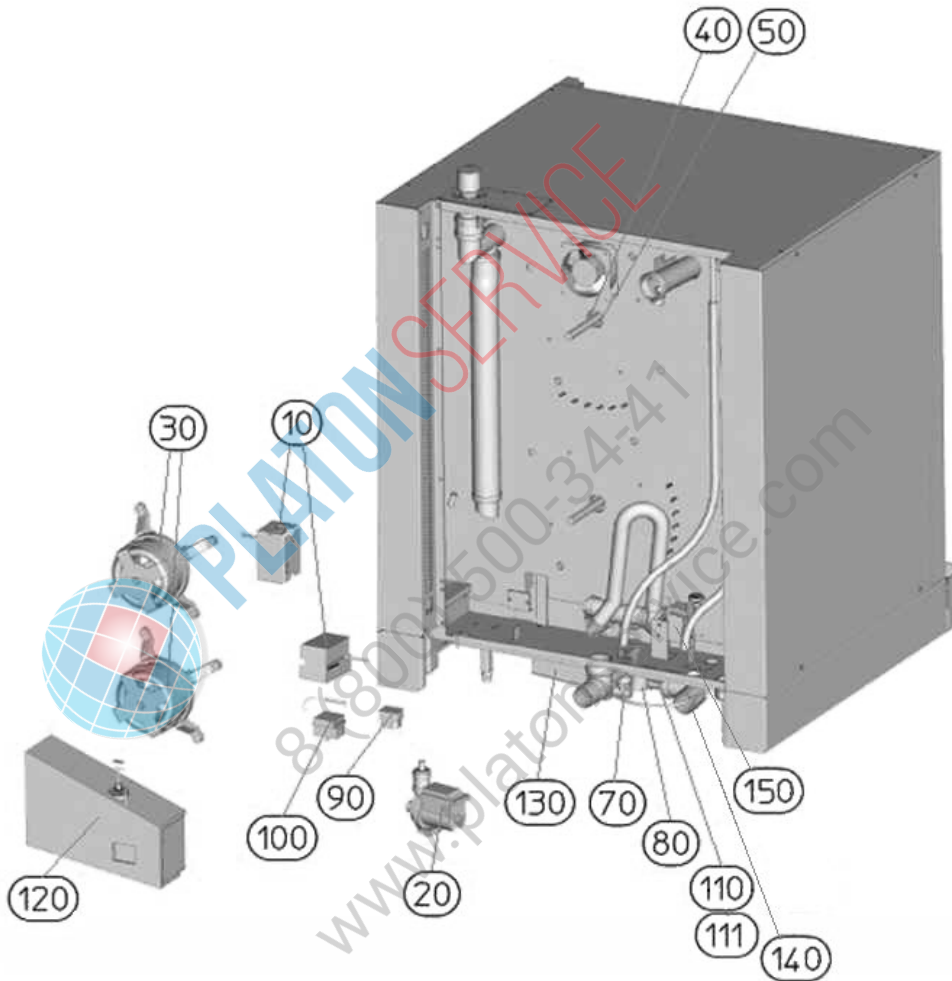

Chapter

boiler steaming Euromat M16-E2-TS 400 50Hz - V:
steam producer Euromat M16-E2-TS 400 50Hz - V:

- [010] - 38816 - fan reversing switch
- [020] - 100060 - pump ProClean (version 50Hz)
- [030] - 9020-110-002 - fan motor
- [040] - 04800 - sealing plate
- [050] - 34047 - seal motor shaft
- [070] - 34472 - solenoid valve
- [080] - 36126 - water flow detector flow meter FH20
- [090] - 100627 - safety limit switch (+340°C)
- [100] - 38614 - safety limit switch (+145°C)
- [100] - 9030-145-001 - safety temperature limiter (150°C)
- [110] - 37906 - membrane switch ProClean
- [111] - 40074 - silicone hose
- [130] - 31188 - hydro box
- [140] - 105572 - ball valve 1"
- [150] - 34579 - pump



PLATONSERVICE

8 (800) 500-34-47

www.platonservice.com

Part: fan reversing switch

Pert-Number: 38816

Air intake/output always run parallel and are self synchronizing. They are controlled from the circuit board by the running program. If the air intake/output do not run synchronized it can have a negative influence on the baking products. NOTE: When replacing the cam shaft ensure that the control unit have the processing date of 0/26 or 0/25 with the additional notation "check" or "green point" so that the units do not run asynchronous.



Part: pump ProClean (version 50Hz)

Pert-Number: 100060

The ProClean pump is a circulating pump. The pump extracts and transports the cleaning water. The operation can be controlled by the power element, operating control and software. A ProClean pump function test can be done in PC-Tool-Test. Warning! The PC Tool Function test is an endurance test and is not protected against overload!



Part: fan motor

Pert-Number: 9020-110-002

For improved baking results the Hanning Motor has two rotating directions and several speeds. In ovens with the IS Control the speed is regulated by the Triac setter. In ovens with a manual control the contactor regulates the speed. The motor is secured with 4 M 6 nuts. The distance sleeves screws that are fixed by locknuts must always have the same height. Tighten the nuts diagonally to avoid tension. The motor has a built in thermo protection (bimetal) that activates at 160° C and automatically resets when cooled down. When the motor protection is activated the motor function is interrupted. Note that you should avoid speeds under 3 in the baking programs. If the fan wheel doesn't move easily or is unbalanced the motor spool may overheat. The thermo safety of the motor will activate and the complete operation will be interrupted. Check the fan wheel for imbalancing. Replace the fan. If a new motor is installed a new motor shaft seal (article number 34047) must be used. Also, the counternuts must be diagonally fastened to avoid tension. The motor has a built in thermo protection (bimetal) that activates at 160° C and automatically resets when cooled down.



Part: sealing plate

Pert-Number: 04800

The sealing plate secures the motor shaft. Pull the motor first when installing and the sealing plate at the end.



Part: seal motor shaft

Pert-Number: 34047

The motor shaft seal is a clean lead and seal against moisture at the back of the oven which could lead to disturbances. Therefore the following must be observed: Tighten the sealing plate after the motor is fastened, otherwise the motor shaft seal on the motor shaft is not guaranteed. This motor shaft seal must be replaced with each motor installation.



Part: solenoid valve

Pert-Number: 34472

It is necessary to clean the dirt sieve of the solenoid valve regularly. Particles in the water line will stick to the sieve and interrupt the water flow. Please note the maximum water pressure and other warnings from the data sheets regarding the water connection. The solenoid valve works with a flow pressure of 150 - 600 kPa. You can test the solenoid valve function in the PC - Tool - Test. Attention the test is a continued test and this function is not protected from overload.



Part: water flow detector flow meter FH20

Pert-Number: 36126

The flow meter measures the water flow amount. When installing, pay attention to the polarity +/- of the impulse meter (Hall sensor).



Part: safety limit switch (+340°C)

Pert-Number: 100627

The safety temperature limit switch (STB) is activated at temperatures of -5°C (and lower) and $+329^{\circ}\text{C}$ (and higher). The oven will not operate when this is activated. The STB is part of the safety chain and can be manually re-set. Warning, when the STB is activated the cause must be resolved. Insulate the capillary tube (e.g. on the circuit board) on its critical spots with silicone hose Article number 40074.



Part: safety limit switch (+145°C)

Pert-Number: 38614

The safety (STB) is at a temperature of -5°C (and down) and $+145^{\circ}\text{C}$ (and higher) are triggered. If the STB are not triggered functions given by the stove. The STB is part of the security chain and can be reset manually. Attention has raised the STB to the possible causes of triggering to be removed. Insulate the capillary tube at critical points (for example on boards) with silicone tubing article 40074.



Part: safety temperature limiter (150°C)

Pert-Number: 9030-145-001

Part: membrane switch ProClean

Pert-Number: 37906

The switch ProClean serves as a filling amount safety control. If the solenoid valve is over filled then the automatic self cleaning will not function. The pressure switch activates at 16mbar. The activation of the motor, heater and solenoid valve will be interrupted.



Part: silicone hose

Pert-Number: 40074



Part: hydro box

Pert-Number: 31188

In the hydro-box all the parts that are associated with the water are combined. Such as drain door, discharge chamber and discharge pump boiler. In the hydro-box is a type K thermocouple which controls in conjunction with the sensor chamber via the control board the moisture. Malfunctions of the moisture regulation should the thermocouple on clean seat (ie solid, pushed up to the stop) and pollution be reviewed. Furthermore, care must be taken out is that the drain (chamber) is always kept clean, otherwise there may be disturbances occur in the moisture regulation. When installing the thermocouple is to respect the polarity. Please, note the "Documents" link.



Part: ball valve 1"

Pert-Number: 105572



Part: pump

Pert-Number: 34579



PLATON SERVICE
8 (800) 500-34-47
www.platonservice.com

Service manual boiler steaming Euromat M16-E2-TS 400 50Hz

Version:

Ident:

Series:

Pert-Number:



Chapter

- [010] - 30899 - boiler
- [020] - 34566 - hose clamp 8-16 DIN 3017
- [030] - 33524 - HT - hose silicone D 18xS3 LW12
- [040] - 42237 - hose clamp 12-22/13A2
- [050] - 100208 - reduction double nipple
- [060] - 100060 - pump ProClean (version 50Hz)
- [070] - 34472 - solenoid valve
- [080] - 09452 - pipe for injector
- [090] - 100835 - connection pipe
- [100] - 36037 - silicone hose transparent

PLATON SERVICE
8 (800) 500-2247
www.platonservice.com

Part: boiler

Pert-Number: 30899

Due to the built descaling - Automatic (EK), a running descaling of the steam generator is redundant. The steam generator is at certain time intervals, rinsed and drained automatically. The accumulated calcium is transported out here. At normal water hardness (water quality, minimum conductivity $100 \text{ } \mu\text{S} / \text{cm}$), the steam generator every 4 months decalcified. In addition, the steam generator once every 12 months receive a basic cleaning. This should be done by a qualified service. If a water hardness can be hard to very hard use, ie 14-21 degrees of hardness, is the installation of a water treatment plant or a monthly descaling required.



Part: hose clamp 8-16 DIN 3017

Pert-Number: 34566



Part: HT - hose silicone D 18xS3 LW12

Pert-Number: 33524



Part: hose clamp 12-22/13A2

Pert-Number: 42237



Part: reduction double nipple

Pert-Number: 100208



Part: pump ProClean (version 50Hz)

Pert-Number: 100060

The ProClean pump is a circulating pump. The pump extracts and transports the cleaning water. The operation can be controlled by the power element, operating control and software. A ProClean pump function test can be done in PC-Tool-Test. Warning! The PC Tool Function test is an endurance test and is not protected against overload!



Part: solenoid valve

Pert-Number: 34472

It is necessary to clean the dirt sieve of the solenoid valve regularly. Particles in the water line will stick to the sieve and interrupt the water flow. Please note the maximum water pressure and other warnings from the data sheets regarding the water connection. The solenoid valve works with a flow pressure of 150 - 600 kPa. You can test the solenoid valve function in the PC - Tool - Test. Attention the test is a continued test and this function is not protected from overload.



Part: pipe for injector

Pert-Number: 09452



Part: connection pipe

Pert-Number: 100835



Part: silicone hose transparent

Pert-Number: 36037



Service manual steam producer Euromat M16-E2-TS 400 50Hz

Version:

Ident:

Series:

Pert-Number:

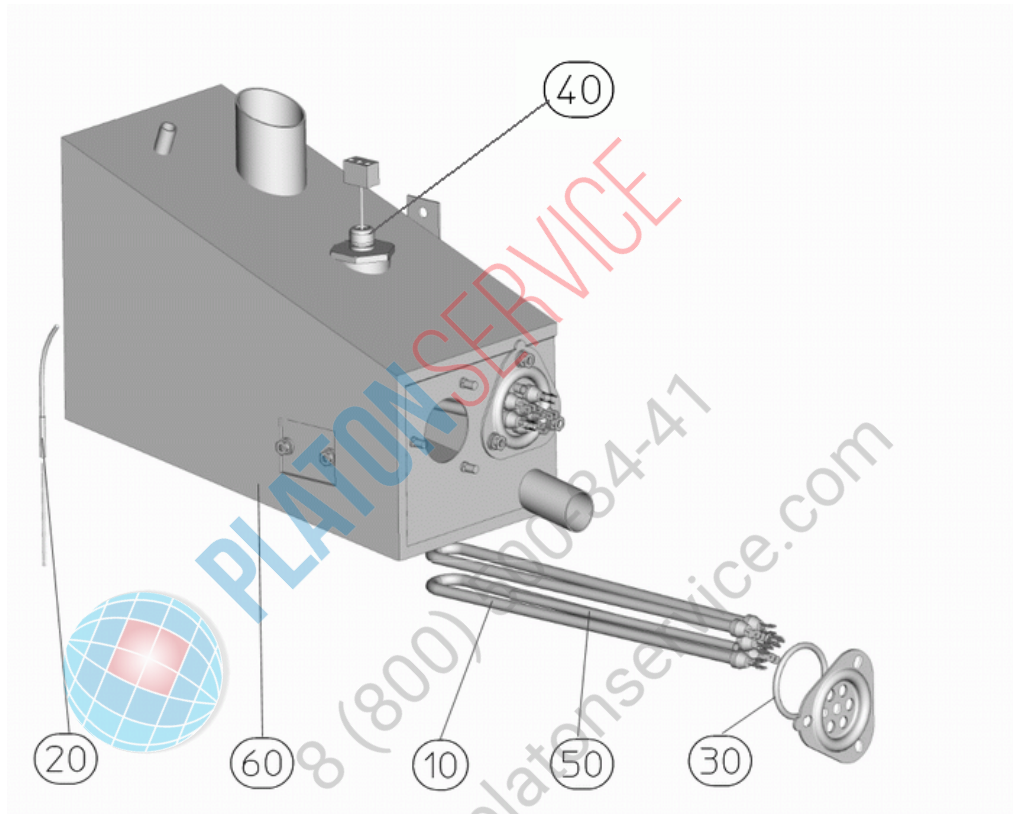

Chapter

- [010] - 34950 - heating element (boiler)
- [020] - 36287 - thermo element Typ K
- [030] - 34470 - seal boiler heater
- [040] - 36090 - level electrode
- [050] - 38614 - safety limit switch (+145°C)
- [050] - 9030-145-001 - safety temperature limiter (150°C)
- [060] - 30899 - boiler

Part: heating element (boiler)

Pert-Number: 34950

About the boiler heating system is contained in the boiler heats water and provides the chamber with steam. The boiler must be de-scaled regularly to avoid premature release of the safety thermostat, for lime insulated warmth. The measurement of the boiler temperature using a thermocouple type K, which also regulates the temperature in the boiler.



Part: thermo element Typ K

Pert-Number: 36287

=> replaced by 104610 The thermo element type K is used as an oven probe. The oven probe controls the oven temperature. The working range is between 30 - 250°C. Please note the polarity (+/-) when replacing the thermo elements. To prevent false measurements the probe must be inserted as far as it will go. Ensure that the oven probe feeds through the fan cover into the oven. The probe must not be in contact with the fan cover - false measurements or even deactivating the safety chain may be the result of coming in contact. If the probe is too short and does not fit into the oven, a probe extension is necessary. Please notice the assembly instructions MH_14-0511-017.



Part: seal boiler heater

Pert-Number: 34470



Part: level electrode

Pert-Number: 36090

About the boiler heating system is contained in the boiler heats water and provides the chamber with steam. The water level is regulated by the electrodes. This level of electrodes may still be afflicted with either calcified or silicates with corrosion. An otherwise the water level detection of the steam generator is not possible (zÜberfüllung). Important also the conductivity of water is observed, other than 100 $\mu\text{S} / \text{cm}$ must lie.

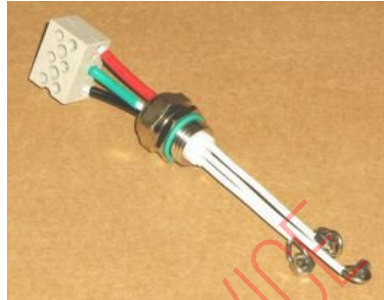

Part: safety limit switch (+145°C)

Pert-Number: 38614

The safety (STB) is at a temperature of -5°C (and down) and $+145^{\circ}\text{C}$ (and higher) are triggered. If the STB are not triggered functions given by the stove. The STB is part of the security chain and can be reset manually. Attention has raised the STB to the possible causes of triggering to be removed. Insulate the capillary tube at critical points (for example on boards) with silicone tubing article 40074.



Part: safety temperature limiter (150°C)

Pert-Number: 9030-145-001

Part: boiler

Pert-Number: 30899

Due to the built descaling - Automatic (EK), a running descaling of the steam generator is redundant. The steam generator is at certain time intervals, rinsed and drained automatically. The accumulated calcium is transported out here. At normal water hardness (water quality, minimum conductivity $100 \text{ } \mu\text{S} / \text{cm}$), the steam generator every 4 months decalcified. In addition, the steam generator once every 12 months receive a basic cleaning. This should be done by a qualified service. If a water hardness can be hard to very hard use, ie 14-21 degrees of hardness, is the installation of a water treatment plant or a monthly descaling required.



PLATON SERVICE
8 (800) 500-34-41
www.platonservice.com

Copyright:

WIESHEU GmbH retains the copyright for this service manual.
This service manual is solely intended for authorised service partners and their personnel.
It contains instructions and information which may not be copied, distributed or otherwise imparted as a whole or in part.

All representations, drawings, images, texts and details are protected by copyright.
They are subject to industrial property rights.

About this service manual:

All figures in this document have the purpose of aiding comprehension. The figures are not to scale. In some cases the figures are similar to the original product and may differ slightly.

Important!

Prevent malfunctions or damage caused by wrong spare parts.
We recommend the sole use of WIESHEU original spare parts.

Wiesheu GmbH
Daimlerstraße 10
DE-71563 Affalterbach
Phone: +49 (0)7144 / 3 03-0
Fax: +49 (0)7144 / 3 03-11
Email: info@wiesheu.de
www.wiesheu.de

Rev.: 10/11/2011



PLATON SERVICE

8 (800) 500-34-41

www.platonservice.com